

REF.No:1009950

Code FO:9008002840

Version:2024/01/02

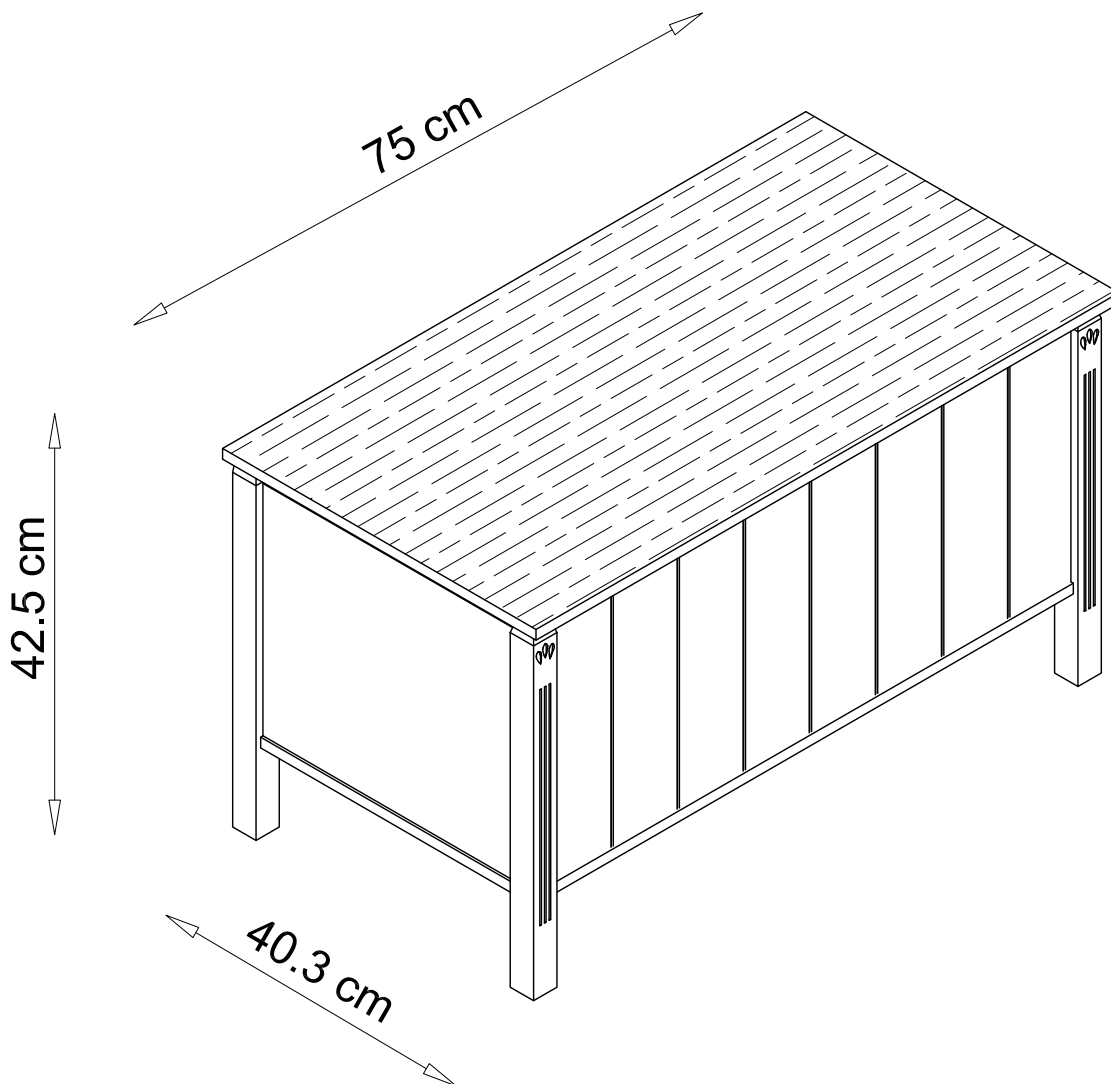

- Vor Montage den Inhalt Ihres Päckchens kontrollieren
- Die Verpackung nicht zerstören, sie wird Ihnen nützlich sein, um die Teile bei der Montage vor Stößen und Kratzern zu schützen
- Das Möbel dann in der Reihenfolge der Nummerierung zusammenbauen
- Im Problemfall Ihren Kundendienst anrufen
- Lüften Sie Ihre Möbel nach dem Aufbau bitte mit geöffneten Möbeltüren und-schubladen in einem gut durchlüfteten Raum.



- Controlar el contenido de su embalaje antes de proceder al montaje
- No deteriorar el paquete, que le será muy útil para proteger los elementos de golpes y rozaduras durante el montaje.
- Acoplar de seguida el mueble, siguiendo la orden definida por la numeración
- Si tiene problemas, contactar nuestro servicio postventa
- Desde la recepción, ventilar los muebles, con las puertas y cajones abiertos, en una estancia bien ventilada. Renovar regularmente el aire de las estancias



- Verificare il contenuto della confezione prima del montaggio.
- Non eliminare l'imballo che potrà essere utilizzato per proteggere il prodotto dai danni durante il montaggio.
- Montare l'articolo seguendo l'ordine di numerazione.
- In caso di necessità contattare il nostro servizio post-vendita.
- Al ricevimento, areare i vostri mobili, aprendo porte e cassetti, in una stanza ben ventilata. Ricambiare l'aria della stanza regolarmente



- De inhoud van uw pakket controleren alvorens met de montage te beginnen
- De Verpakking niet beschadigen, deze kan heel handig zijn om de onderdelen te beschermen tegen schokken en krassen tijdens de montage.
- Zet vervolgens het meubel in elkaar in de volgorde die is bepaald in de nummering
- Neem bij problemen contact op met onze klantenservice.
- Laat na ontvangst uw meubels luchten (deuren en laden open) in een goed geventileerde ruimte. Zorg regelmatig voor frisse lucht in uw kamer



- Contrôler le contenu de votre colis avant de procéder au montage.
- Ne détériorez pas l'emballage, il vous sera très utile pour protéger les éléments des coups et rayures pendant le montage.
- Assemblez ensuite le meuble en suivant l'ordre défini par la numérotation.
- En cas de problème contactez notre service après vente.
- A réception, aérer vos meubles, portes et tiroirs ouverts, dans une pièce bien ventilée. Renouveler régulièrement l'air de vos pièces.



- Check the content of your parcel before assembling.
- Do not throw away the packing which could be very useful to protect the panels from knocks and scratches when assembling.
- Assemble the article following the order of the numbers indicated.
- Should any problems arise, please contact our After Sale Service.
- Upon receipt, place the furniture in a well-ventilated room and leave doors and drawers open to allow the air to circulate. Change the air in your rooms on a regular basis.



- Confira o conteúdo da sua encomenda antes de iniciar a montagem.
- Não danifique a embalagem, poderá ser-lhe útil para proteger os elementos de golpes ou riscos durante a montagem.
- Proceda à montagem do móvel seguindo a ordem definida pela numeração.
- Para qualquer esclarecimento, contacte os nossos serviços através do telefone.
- Quando da sua recepção, arejar os seus móveis, portas e gavetas abertas, numa divisão bem ventilada. Renovar regularmente o ar das suas divisões.

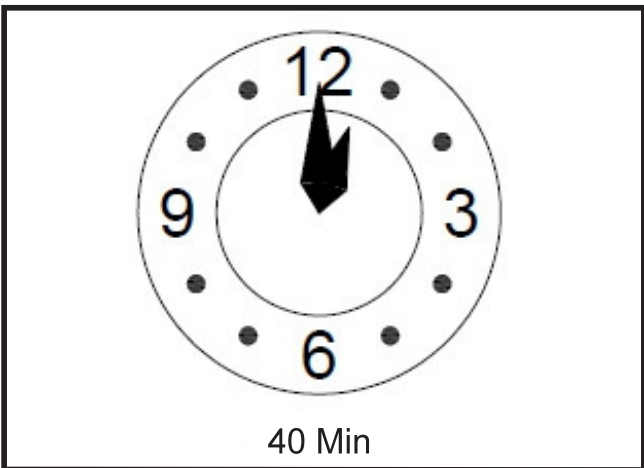
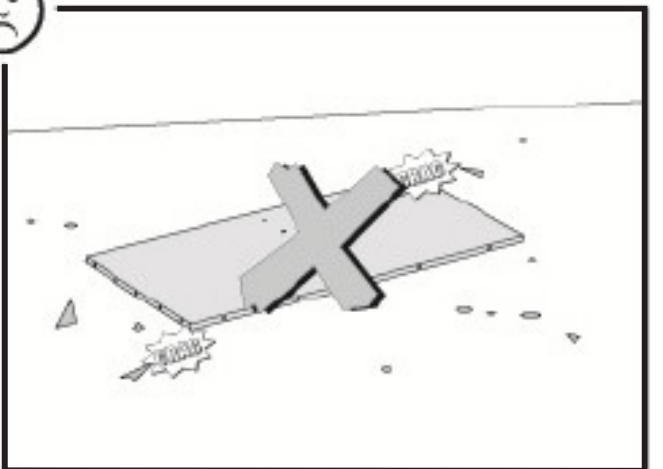
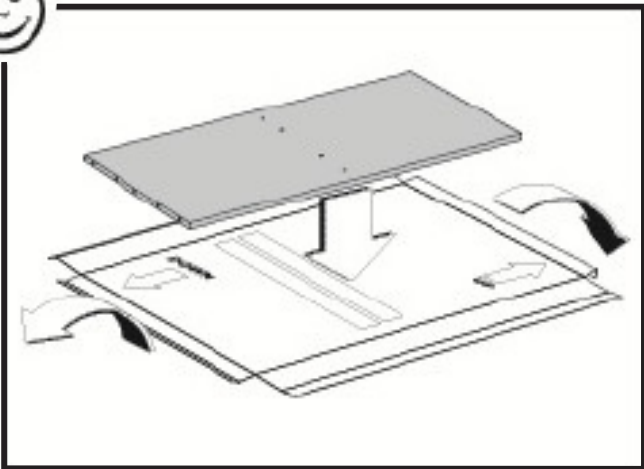
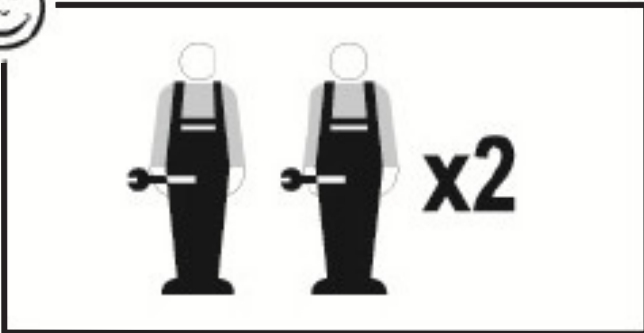
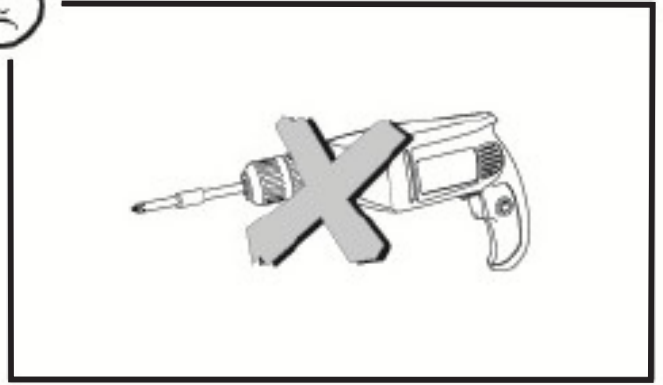
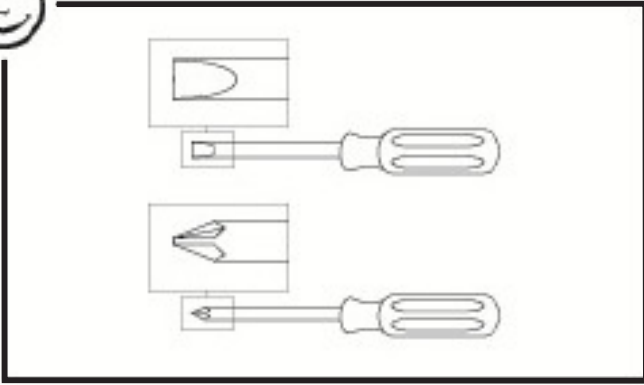

FR - Notice de montage / EN - Assembly instructions / PT - Instruções de montagem /  
ES - Prospecto de montaje / DE - Montageanleitung / IT - Istruzioni di montaggio /  
NL - Montagehandleiding

## FR - IMPORTANT ! A LIRE ATTENTIVEMENT ET A CONSERVER EN VUE D'UNE CONSULTATION ULTERIEURE

- A monter par un adulte. Un adulte doit vérifier le bon assemblage avant l'emploi
- ATTENTION! tenir les vis et petits éléments et sachets hors de portée des enfants
- Bien identifier les éléments avant de commencer le montage
- En cas de problème contactez notre service après-vente
- Toujours suivre les instructions du fabricant
- Ne pas monter sur le produit
- Entretien: nettoyer avec un chiffon doux et sec. En cas de taches plus grosses, frottez soigneusement avec une éponge légèrement humide et non abrasive
- AVERTISSEMENT - Si ce produit est placé sous une fenêtre, il peut servir de marche à l'enfant et entraîner sa chute par la fenêtre
- AVERTISSEMENT - Tenir compte des risques engendrés par la présence de foyers ouverts ou autres sources de forte chaleur à proximité immédiate du produit
- AVERTISSEMENT - NE PAS placer ce produit à proximité d'une fenêtre où les cordons de stores ou de rideaux pourraient étrangler un enfant
- Il convient de toujours serrer correctement tous les dispositifs d'assemblage
- Ne pas utiliser ce produit si une pièce est cassée, déchirée ou manquante et utiliser uniquement des pièces de rechange approuvées par le fabricant
- Âge de l'enfant auquel le siège est destiné : ≥ 6 ans
- Conforme à la norme EN 17191 :2021
- Charge maximale : 75 kg

## EN - IMPORTANT! READ CAREFULLY AND KEEP FOR FUTURE REFERENCE

- To be assembled by an adult. Assembly must be checked by an adult before use
- WARNING! keep all screws, small parts and plastic bags out of the reach of children
- Properly identify all parts before assembling
- Should any problems arise, please contact our After Sales Service
- Manufacturer's instructions shall be followed at all times
- Do not climb on the product
- Care: clean with a soft, dry cloth. In case of larger stains, carefully rub with a slightly damp, non-abrasive sponge
- WARNING - If this product is located under a window, it can be used as a step by the child and cause the child to fall out of the window
- WARNING - Be aware of the risk of open fires and other sources of strong heat in the vicinity of the product
- WARNING - DO NOT place this product near a window where cords from blinds or curtains may strangle a child
- All assembly fittings should always be tightened properly
- Do not use the product if any part is broken, torn or missing and use only spare parts approved by the manufacturer
- Age of the child for which the seating is intended: ≥ 6 years
- Complies with standard EN 17191 :2021
- Maximum loading : 75 kg

## PT - IMPORTANTE! LEIA ATENTAMENTE E GUARDE PARA CONSULTA FUTURA

- A ser montado por um adulto. Um adulto deve verificar a boa montagem antes da utilização
- ATENÇÃO! mantenha os parafusos, acessórios pequenos e saco de plástico fora do alcance das crianças
- Identifique bem os acessórios antes de começar a montagem
- Para qualquer esclarecimento, contacte os nossos serviços através do telefone
- As instruções do fabricante devem ser sempre cumpridas
- Não suba para cima do produto
- Manutenção: limpe com um pano macio e seco. Em caso de manchas maiores, esfregue cuidadosamente com uma esponja ligeiramente húmida e não abrasiva
- AVISO - Se este produto for colocado sob uma janela, pode servir de degrau à criança e fazer com que caia da janela
- AVISO - Tenha em conta os riscos provocados pela presença de chamas livres e outras fontes de calor intenso na proximidade do produto
- AVISO - NÃO coloque este produto na proximidade de uma janela onde as fitas das persianas ou das cortinas possam estrangular a criança
- Todos os acessórios de montagem devem ser sempre fixados corretamente
- Não utilize este produto se uma peça estiver partida, rasgada ou em falta e utilize apenas peças de substituição aprovadas pelo fabricante
- Idade da criança à qual o assento se destina: ≥ 6 anos
- Em conformidade com a Norma EN 17191 :2021
- Carga máxima: 75 kg

# ES - ¡IMPORTANTE! LEA DETENIDAMENTE ESTAS INDICACIONES Y GUÁRDELAS PARA FUTURAS CONSULTAS

- A montar por un adulto. Un adulto debe comprobar el buen montaje antes de la utilización
- ¡ADVERTENCIA! mantener los tornillos, los pequeños elementos y bolsitas fuera del alcance de los niños
- Identificar debidamente los elementos antes de empezar el montaje
- Si tiene problemas, contactar nuestro servicio postventa
- Deben seguirse siempre las instrucciones del fabricante
- No subir sobre el producto
- Cuidados: limpiar con un paño suave y seco. En caso de manchas grandes, frotar con cuidado utilizando una esponja húmeda no abrasiva
- ADVERTENCIA: Si se coloca el producto bajo una ventana, el niño podría subirse y caer por la ventana
- ADVERTENCIA: Tenga en cuenta el riesgo que generan las llamas abiertas y otras fuentes de calor intenso cerca del producto
- ADVERTENCIA: NO coloque este producto cerca de una ventana donde los cordones de los estores o de las cortinas puedan estrangular a un niño
- Todos los elementos de montaje deberán estar siempre correctamente apretados
- No utilice el producto si alguna pieza está rota, rasgada o falta; y utilice únicamente piezas de repuesto aprobadas por el fabricante
- Edad del niño o la niña a quien se destina el asiento:  $\geq 6$  años
- Conforme a la norma EN 17191 :2021
- Carga máxima : 75 kg

# DE - WICHTIG! AUFMERKSAM LESEN UND FÜR SPÄTERES NACHLESEN AUFBEWAHREN

- Von einem Erwachsenen zu montieren. Die korrekte Montage muss vor Gebrauch von einem Erwachsenen geprüft werden
- ACHTUNG! die Schrauben und kleinen Teile ausserhalb der Reichweite von Kindern lagern
- Vor Montagebeginn alle Teile identifizieren
- Im Problemfall Ihren Kundendienst anrufen
- Stets die Herstelleranweisungen beachten
- Nicht auf das Produkt steigen
- Wartung: Mit einem weichen, trockenen Tuch reinigen. Bei größeren Flecken vorsichtig mit einem leicht feuchten, nicht scheuernden Schwamm abreiben
- WARNHINWEIS- Wenn das Produkt unter einem Fenster steht, kann es von einem Kind als Stufe genutzt werden und dazu führen, dass das Kind aus dem Fenster stürzt.
- WARNHINWEIS- Achten Sie auf Risiken, die durch offene Kamine oder andere starke Hitzequellen in der Nähe des Produkts entstehen können.
- WARNHINWEIS- Dieses Produkt nicht in der Nähe eines Fensters aufstellen, wo die Kordeln von Rollos oder Vorhängen eine Strangulationsgefahr für ein Kind darstellen.
- Alle Befestigungen sollten immer ordnungsgemäß festgezogen werden.
- Dieses Produkt nicht benutzen, wenn ein Teil gebrochen, gerissen ist oder fehlt. Nur vom Hersteller zugelassene Ersatzteile verwenden.
- Alter des Kindes, für das die Sitz bestimmt ist:  $\geq 6$  Jahre
- Entspricht der Norm EN 17191 :2021
- Höchstlast : 75 kg

# IT - IM PORTANTE! LEGGERE CON ATTENZIONE E CONSERVARE PER FUTURO RIFERIMENTO

- Il montaggio deve essere eseguito da un adulto. Un adulto dovrà verificare il corretto montaggio prima dell'uso
- **ATTENZIONE!** tenere le viti ed i componenti di piccole dimensioni lontano dalla portata dei bambini
- Controllare i pezzi prima del montaggio
- In caso di necessità contattare il nostro servizio post-vendita
- Seguire sempre le istruzioni del costruttore
- Non salire sul prodotto
- Manutenzione: pulire con un panno morbido e asciutto. Per le macchine più grandi, strofinare accuratamente con una spugna leggermente umida e non abrasiva
- **AVVERTENZA** - Se questo prodotto è collocato sotto una finestra, può essere utilizzato dal bambino come base per arrampicarsi, con conseguente rischio di caduta dalla finestra
- **AVVERTENZA** - Tenere conto dei rischi connessi alla presenza di fiamme libere o altre fonti di forte calore nelle vicinanze del prodotto.
- **AVVERTENZA** - **NON** mettere questo prodotto vicino a una finestra perché i cordoni di tende o veneziane potrebbero comportare il rischio di strangolamento
- Stringere correttamente tutti i dispositivi di fissaggio
- Non utilizzare il prodotto se uno dei suoi componenti è rotto, danneggiato o mancante e utilizzare solo parti di ricambio approvate dal costruttore.
- Età del bambino al quale è destinato il prodotto:  $\geq 6$  anni
- Conforme alla norma EN 17191 :2021
- Carico massimo : 75 kg

# NL - BELANGRIJK! BELANGRIJK! AANDACHTIG DOORLEZEN EN BEWAREN VOOR LATERE RAADPLEGING

- Moet door een volwassene worden gemonteerd. Voor gebruik moet een volwassene controleren dat het product goed in elkaar is gezet
- **WAARSCHUWING!** schroeven en kleine elementen en zakjes buiten bereik van kinderen houden
- De elementen goed identificeren alvorens met de montage te beginnen
- Neem bij problemen contact op met onze klantenservice
- Volg altijd de instructies van de fabrikant
- Niet op het product klimmen
- Onderhoud: maak schoon met een zachte en droge doek. In geval van grotere vlekken, veeg voorzichtig schoon met een licht bevochtigde en niet-schurende spons
- **WAARSCHUWING** - Als dit product onder een raam wordt geplaatst, kan het door een kind als opstapje worden gebruikt waardoor het kind uit het raam kan vallen.
- **WAARSCHUWING** - Houd rekening met de risico's veroorzaakt door open vuren en andere sterke warmtebronnen in de nabijheid van het product
- **WAARSCHUWING** - Plaats dit product **NIET** in een buurt van een raam waar het koord van een jaloezie of gordijn een kind kan wurgen
- Zorg dat alle bevestigingen op elk moment juist zijn vastgemaakt.
- Gebruik dit product niet als er een onderdeel stuk of gescheurd is of ontbreekt. Gebruik alleen reserveonderdelen die door de fabrikant zijn goedgekeurd
- Leeftijd van het kind waarvoor de zitting is bestemd:  $\geq 6$  jaar
- Volgens EN 17191 :2021 norm
- Maximale belasting : 75 kg

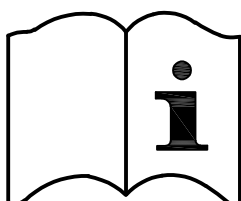

[www.vertbaudet.com](http://www.vertbaudet.com)

LISTE DES ELEMENTS / LIST OF PARTS / LISTA DE ELEMENTOS / LISTON DE ELEMENTOS /  
 TEILELISTE / LISTADEI COMPONENTI / lijst met onderdelen / Osalista / lista över ingående delar

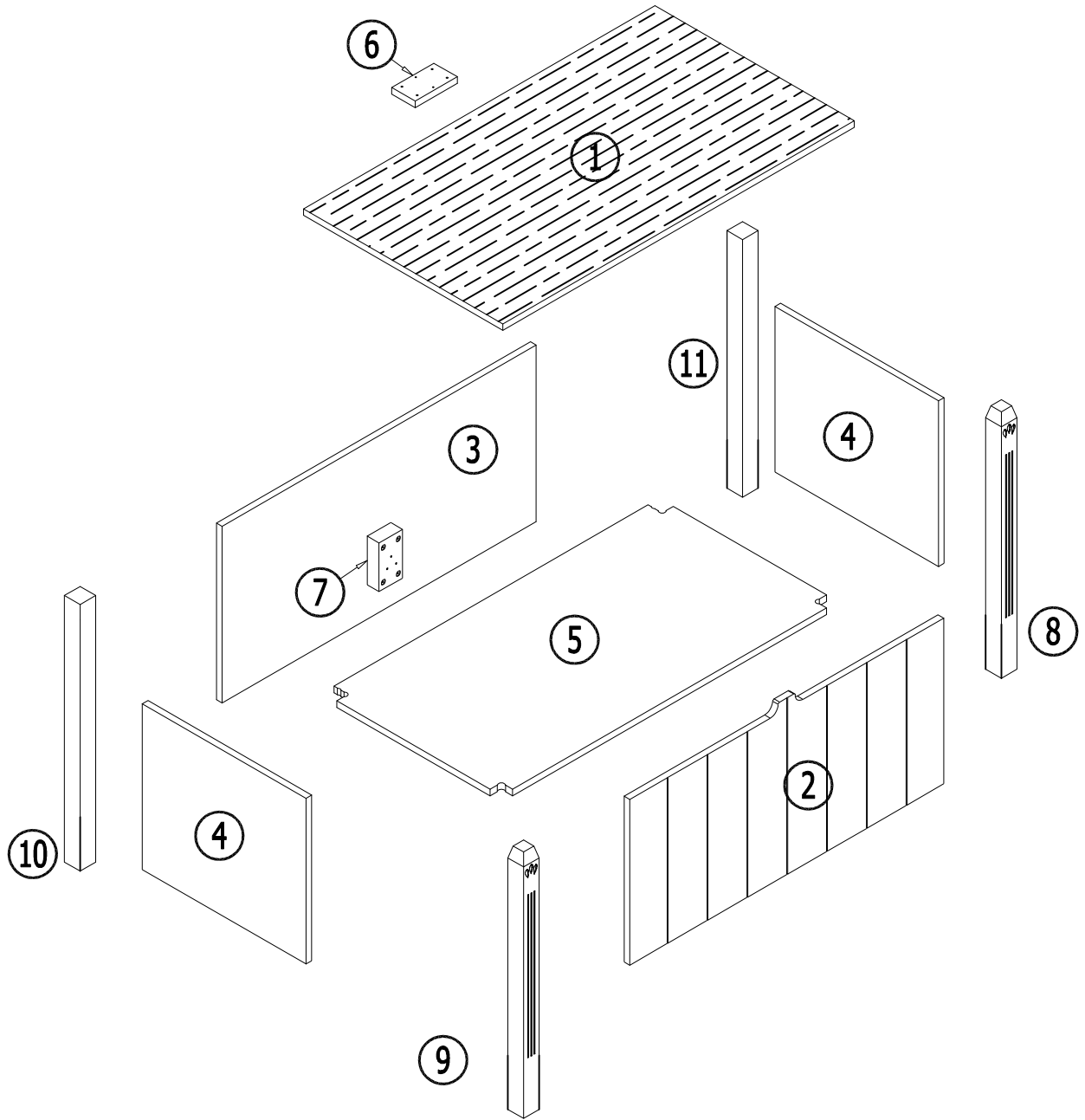

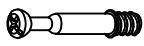

ITEM	HARDWARE	DESCRIPTION	Q'TY	ITEM	HARDWARE	DESCRIPTION	Q'TY
A		Ø6.2*35 mm	24pcs	G		Hinger (41 X 30mm)	3 pcs
B		Ø14.5*9.5 mm	24pcs	H		H1x5 H2 H3 H4	1 SET
C		Ø6*30 mm	24 pcs	K		TF Ø3.8 x 12mm	2 pcs
D		TFØ4*30mm	4 pcs	T		T1 T2	1 SET
E		TFØ4*20mm	4 pcs	U		TF Ø3 x 12 mm	1 pcs
F		TF Ø3 x 10 mm	12 pcs				

1

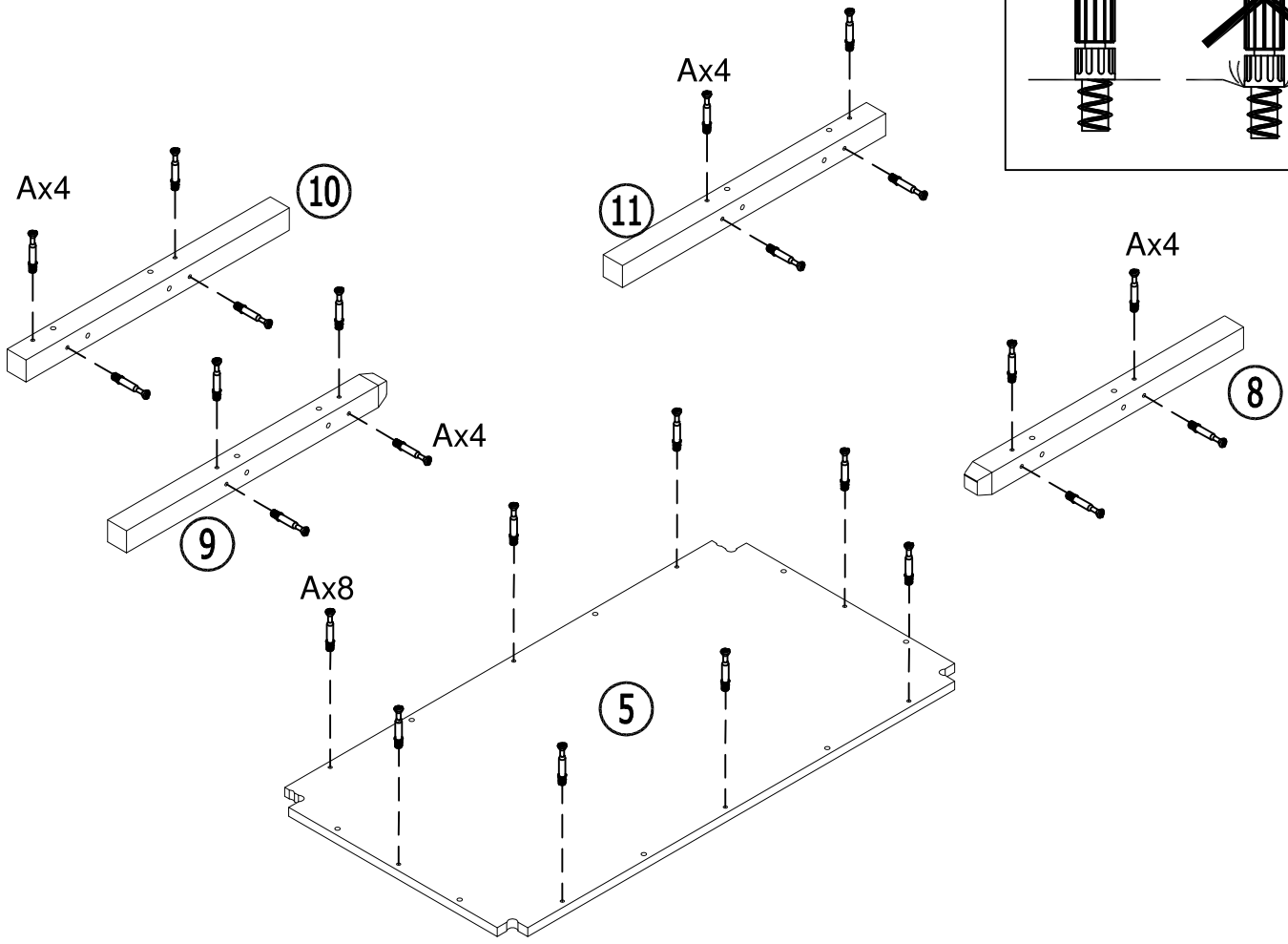
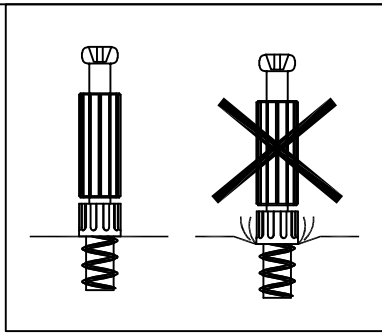
A	x 24
 Ø6.2*35 mm	



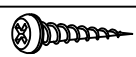
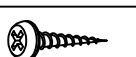

2

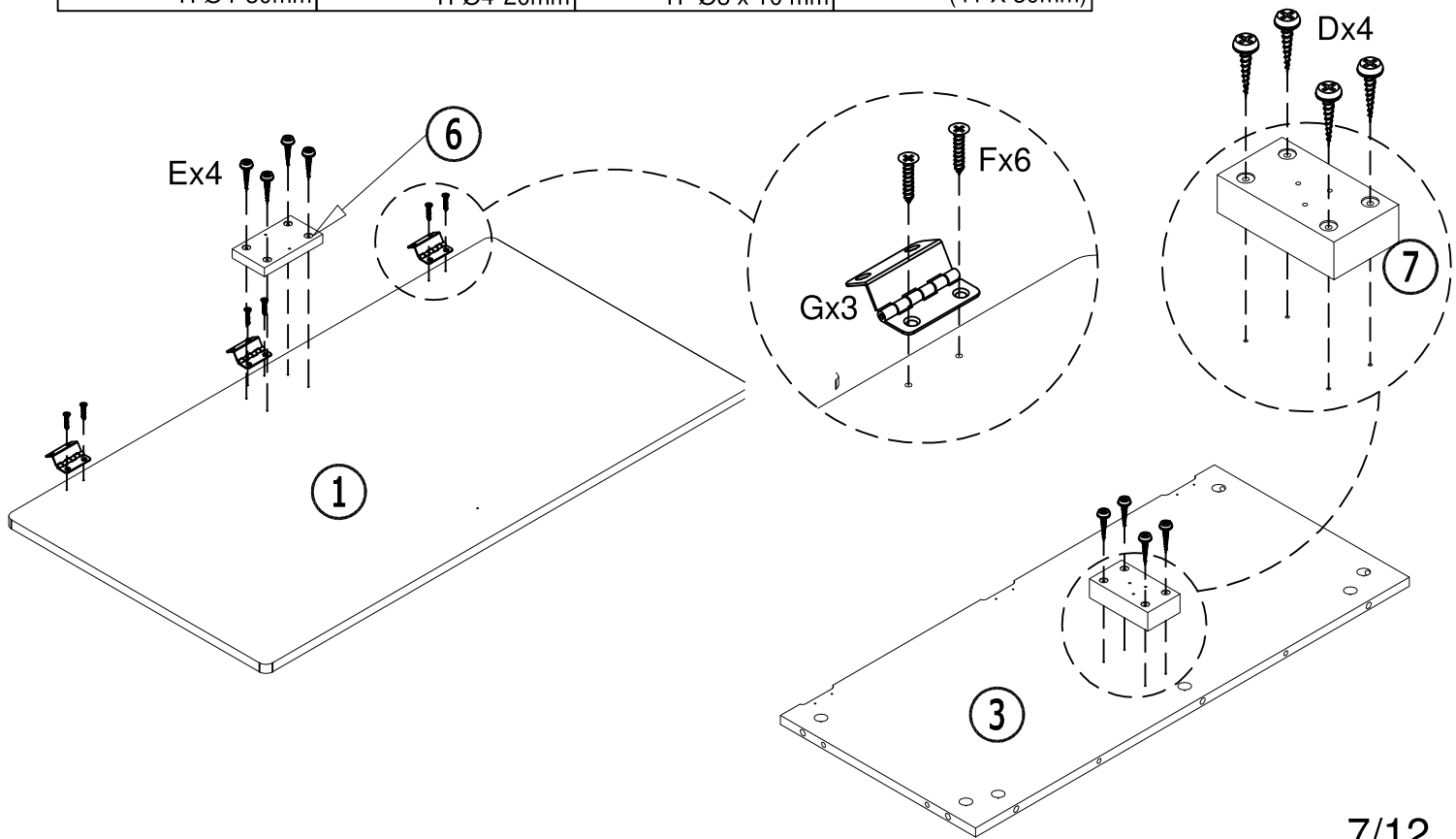
D	x 4	E	x 4	F	x 6	G	x 3
 TFØ4*30mm		 TFØ4*20mm		 TF Ø3 x 10 mm		 Hinger (41 X 30mm)	

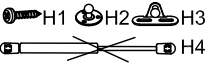

3

U	x 1	H	x 1	T	x 1
					
TF Ø3 x 12 mm				44x15x14 mm	
K	x 2				
					
TF Ø3.8 x 12 mm					

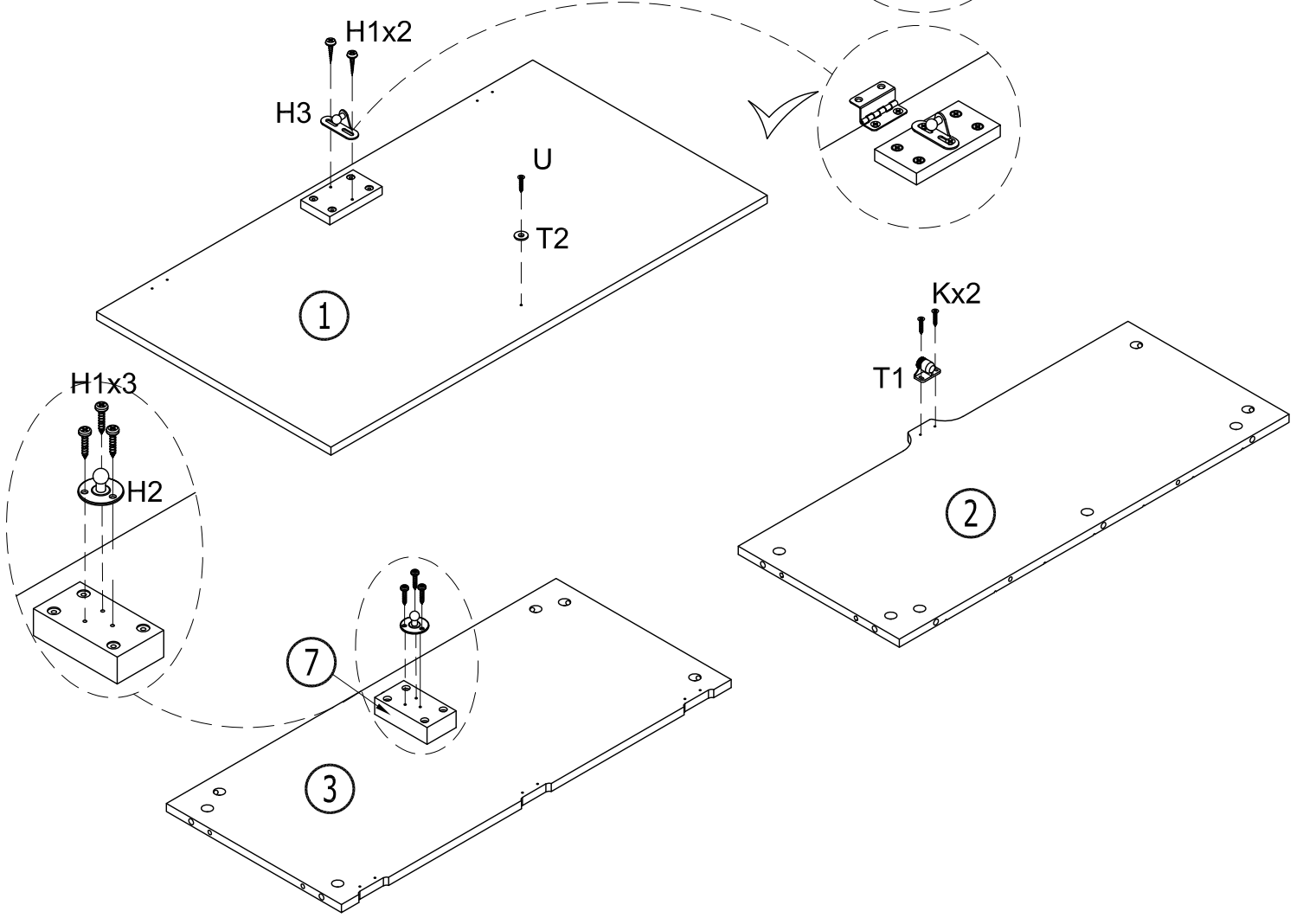

4

C	x 24
	

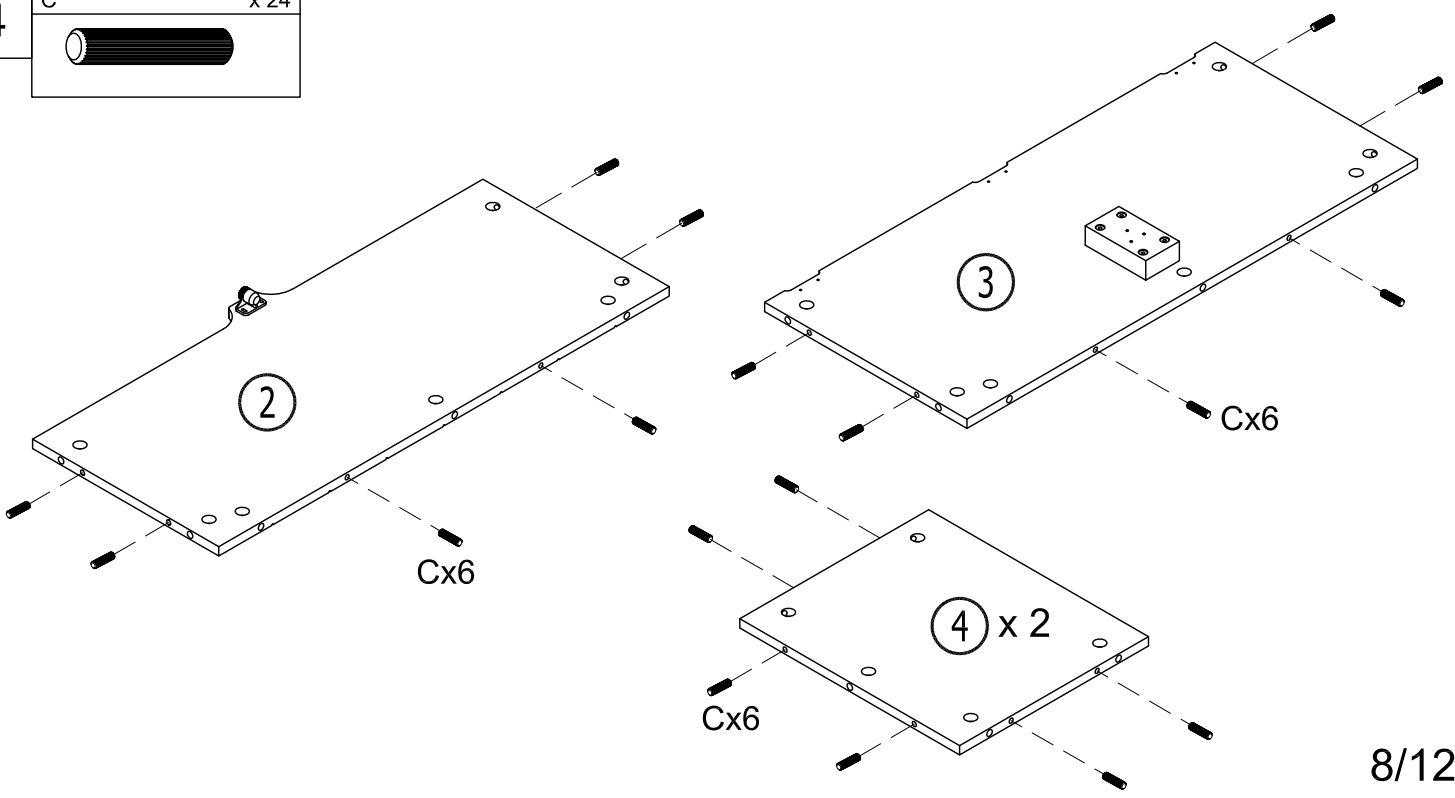



5

B x 8  
Ø14.5\*9.5 mm

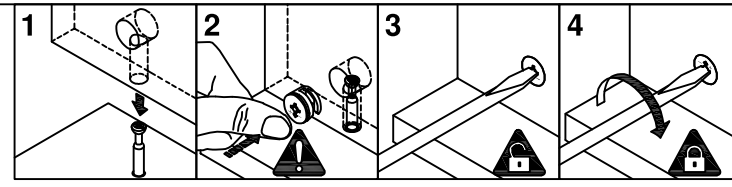
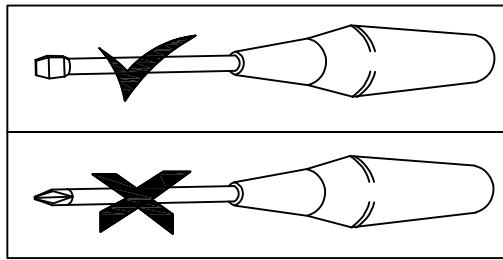

Bx4

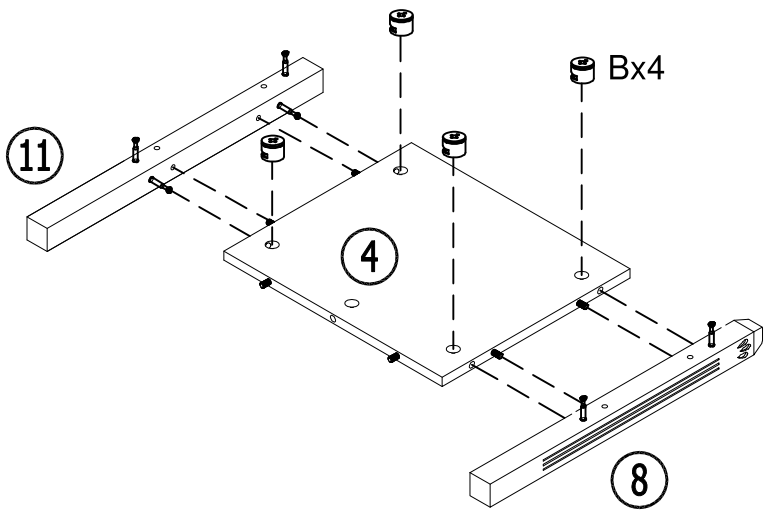
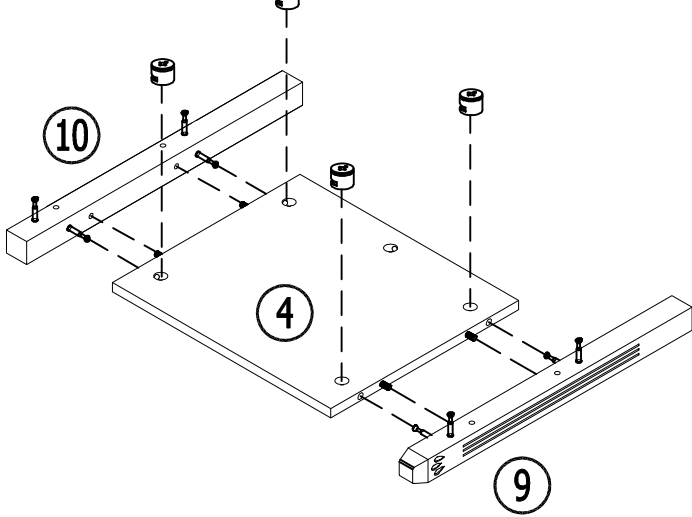

6

B x 8  
Ø14.5\*9.5 mm

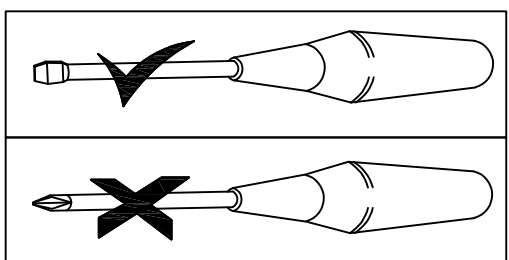
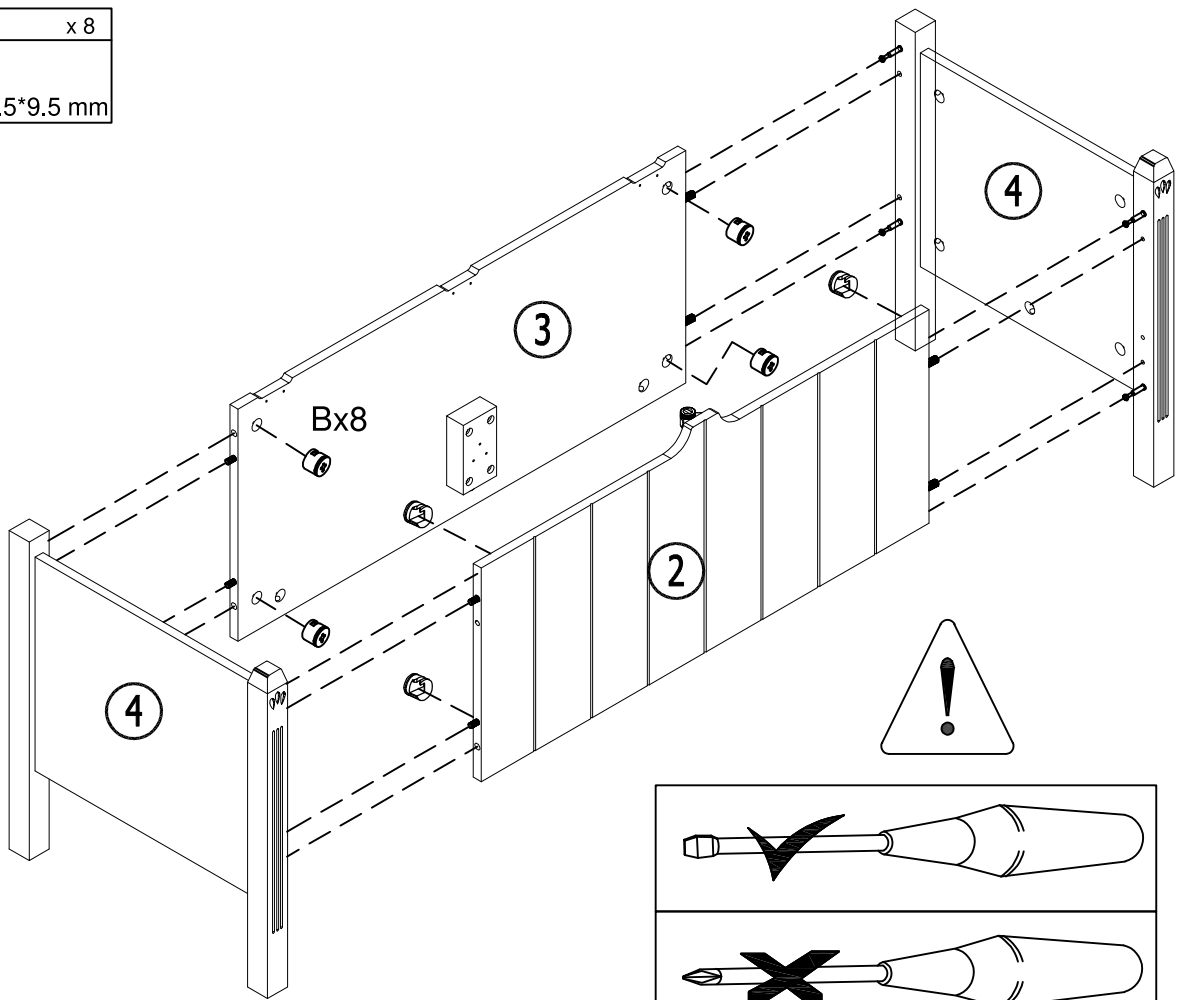
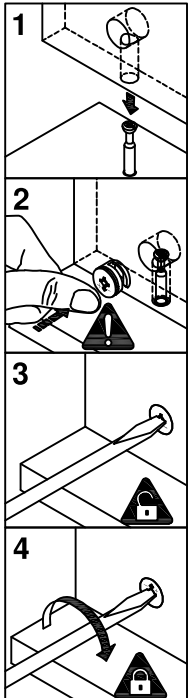

7

B x 8  
Ø14.5\*9.5 mm

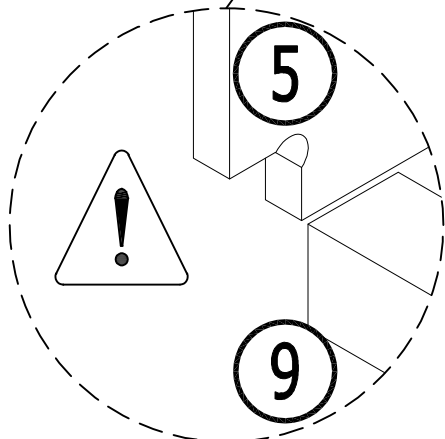
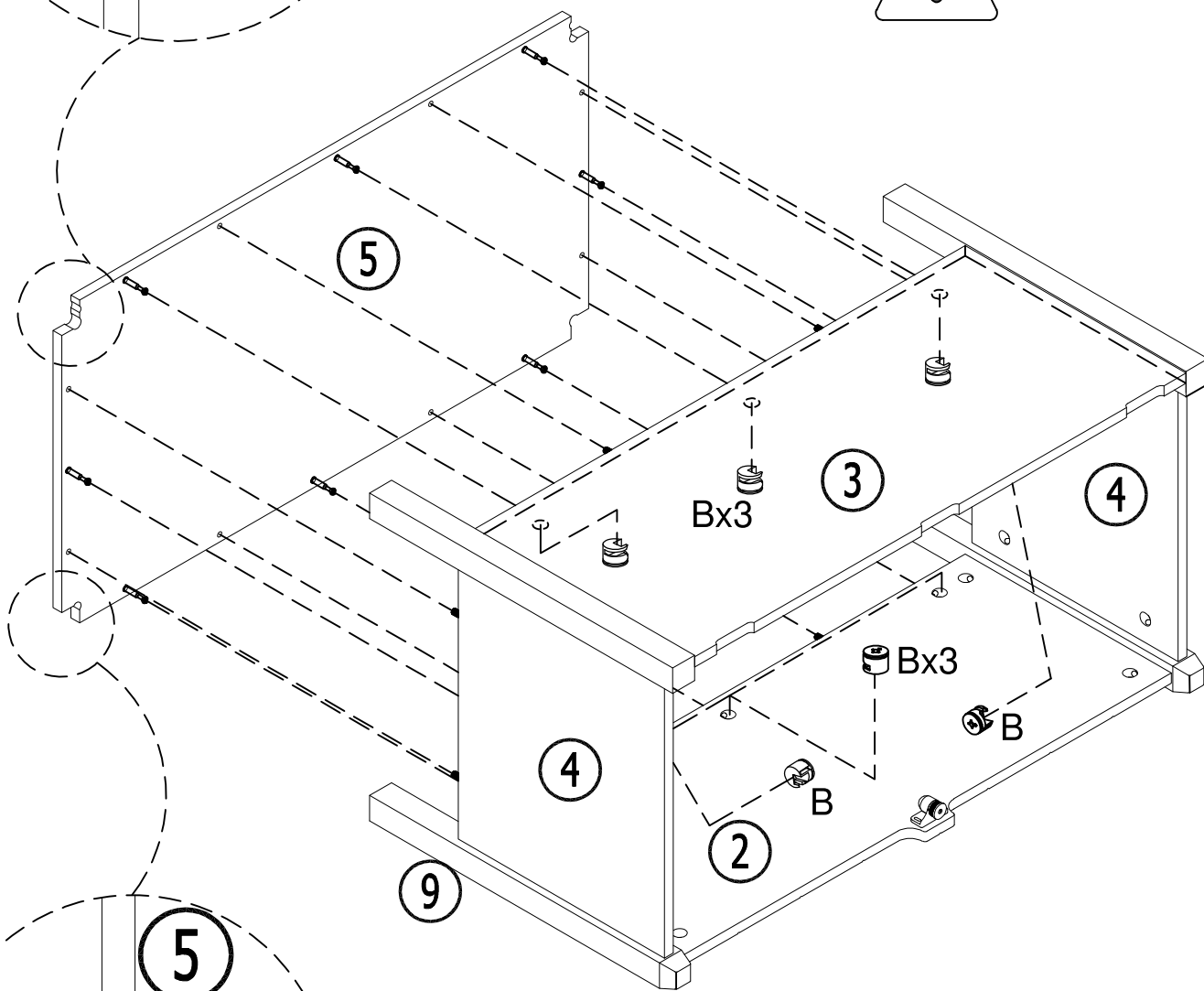
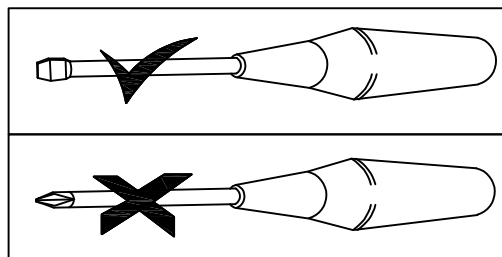
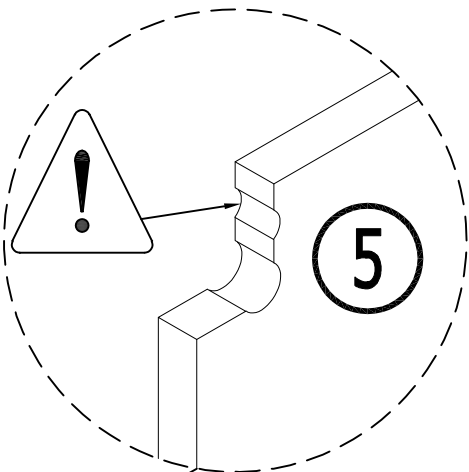
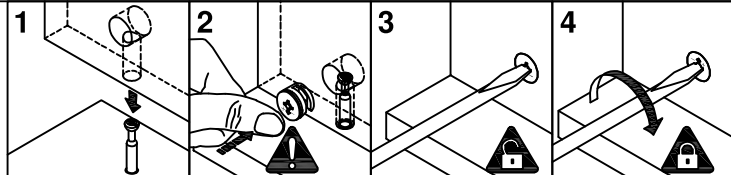

8

F x 6  
TF Ø3 x 10 mm

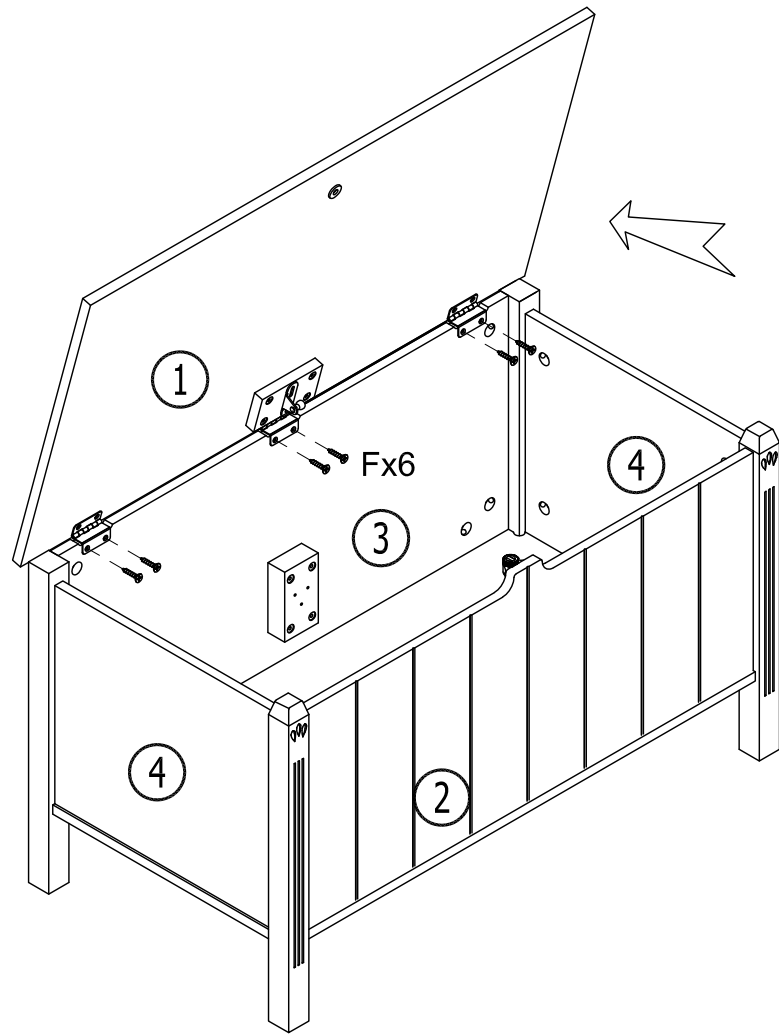

9

H x 1  
H4

1

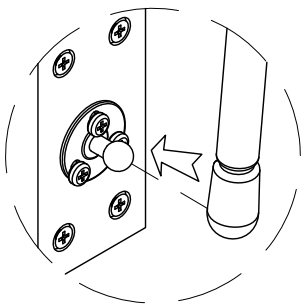

2

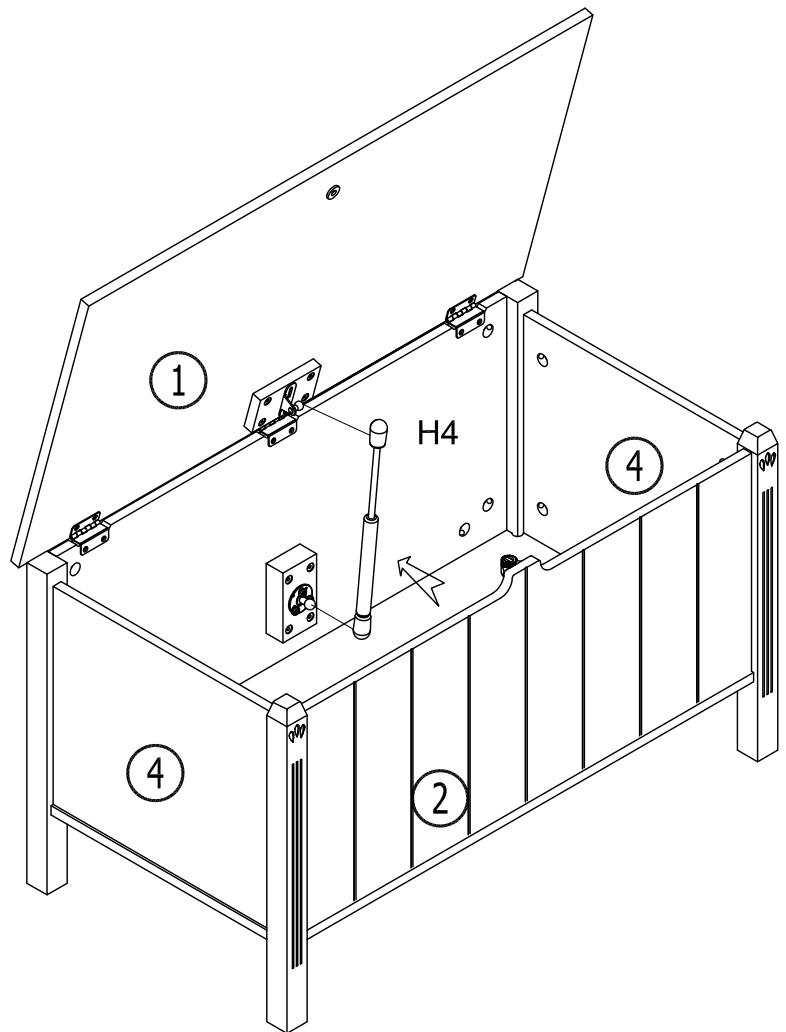
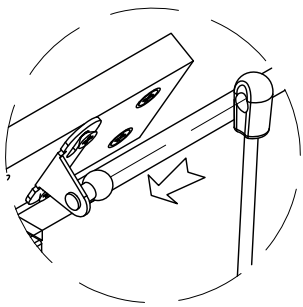

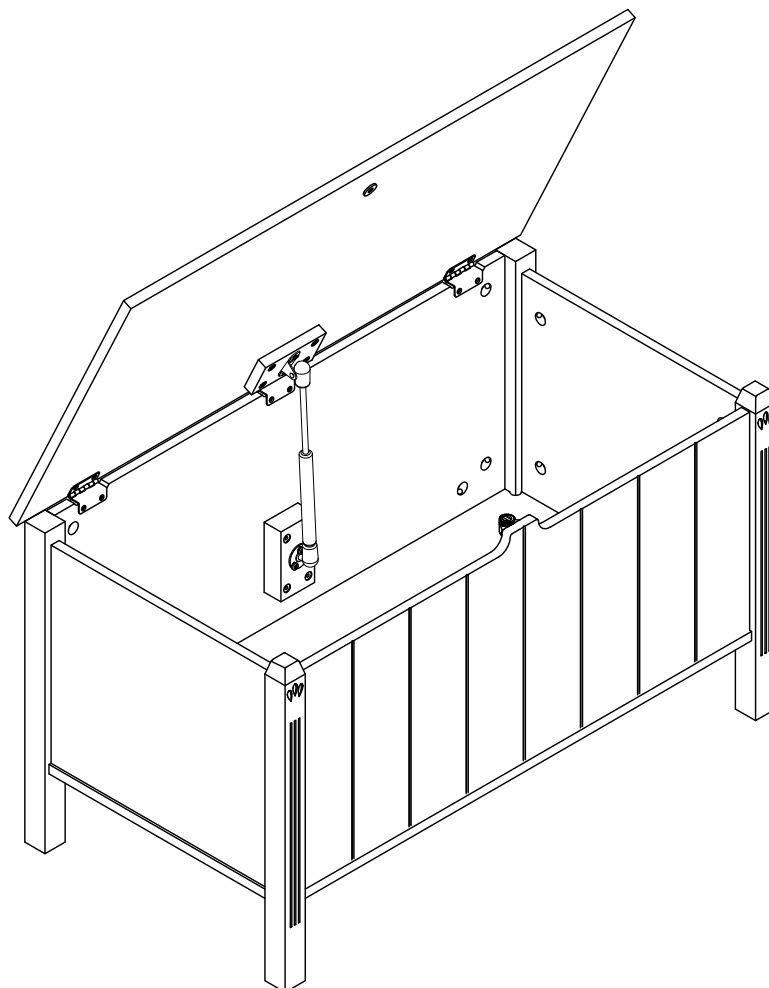

FR-Importé par / EN- Imported by / PT-importado por / ES-importado por / DE-Importiert von / IT-Importato da / NL-Geïmporteerd door :

UE/EU : Vertbaudet SAS - 36 avenue Alfred Lefrançois, 59200 Tourcoing , France

UK : Vertbaudet UK Limited - Elder House, St Georges Business Park, 207 Brooklands Road, Weybridge, Surrey KT13 0TS

